

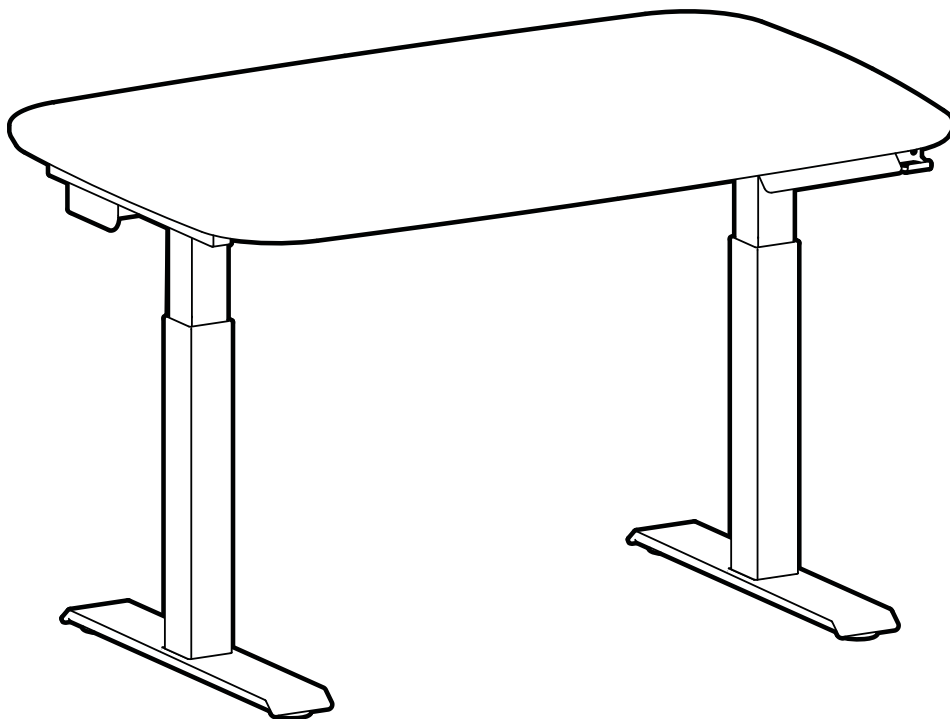

**WORKFIT**<sup>TM</sup>

by **ergotron**<sup>®</sup>

# Electric Sit-Stand Desk



## Tools Needed



## Components

|   | A         | B                    |
|---|-----------|----------------------|
| 1 | <p>1x</p> | <p>1x</p> <p>5mm</p> |
| 2 | <p>1x</p> |                      |



|   | A         | B         | C                           | D         |
|---|-----------|-----------|-----------------------------|-----------|
| 1 | <p>2x</p> | <p>2x</p> | <p>8x</p> <p>M6 x 16 mm</p> | <p>2x</p> |

1

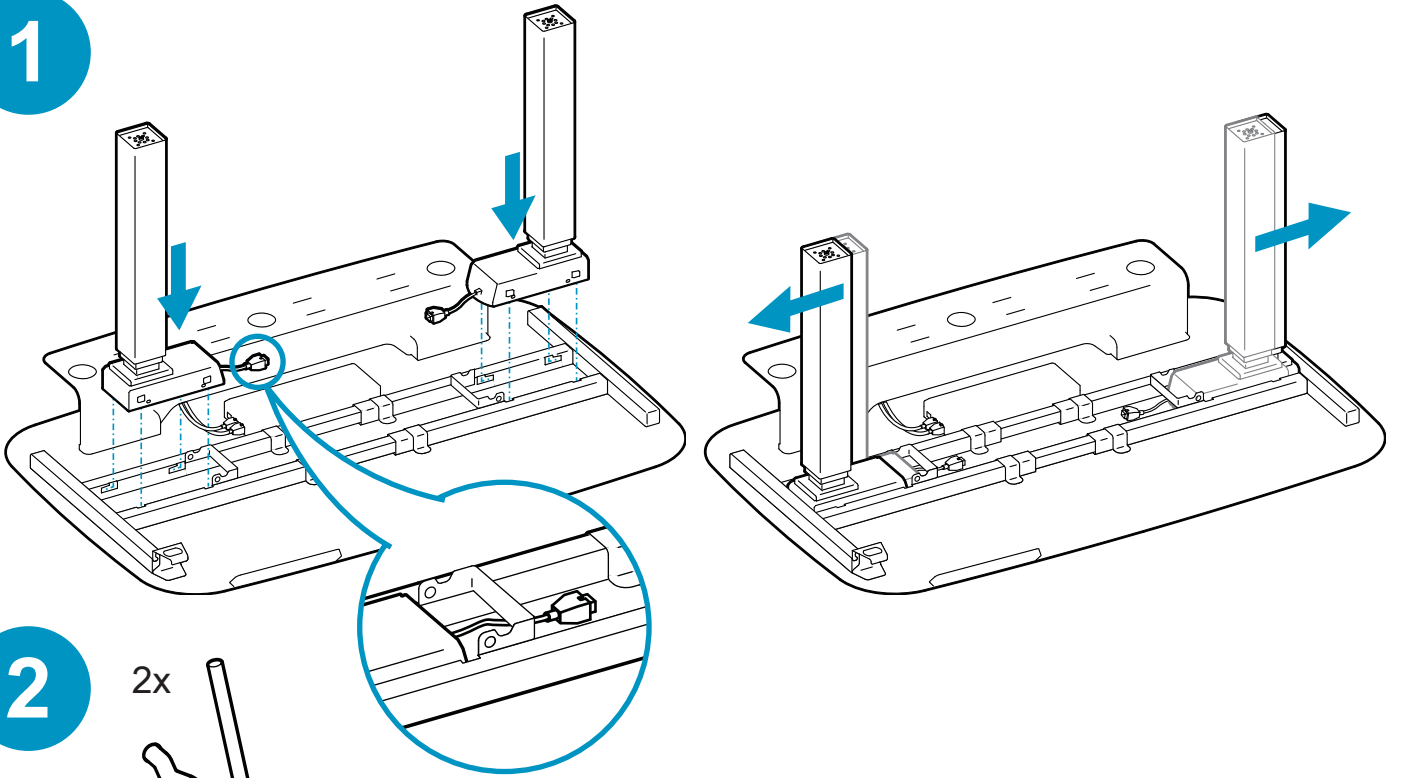

2

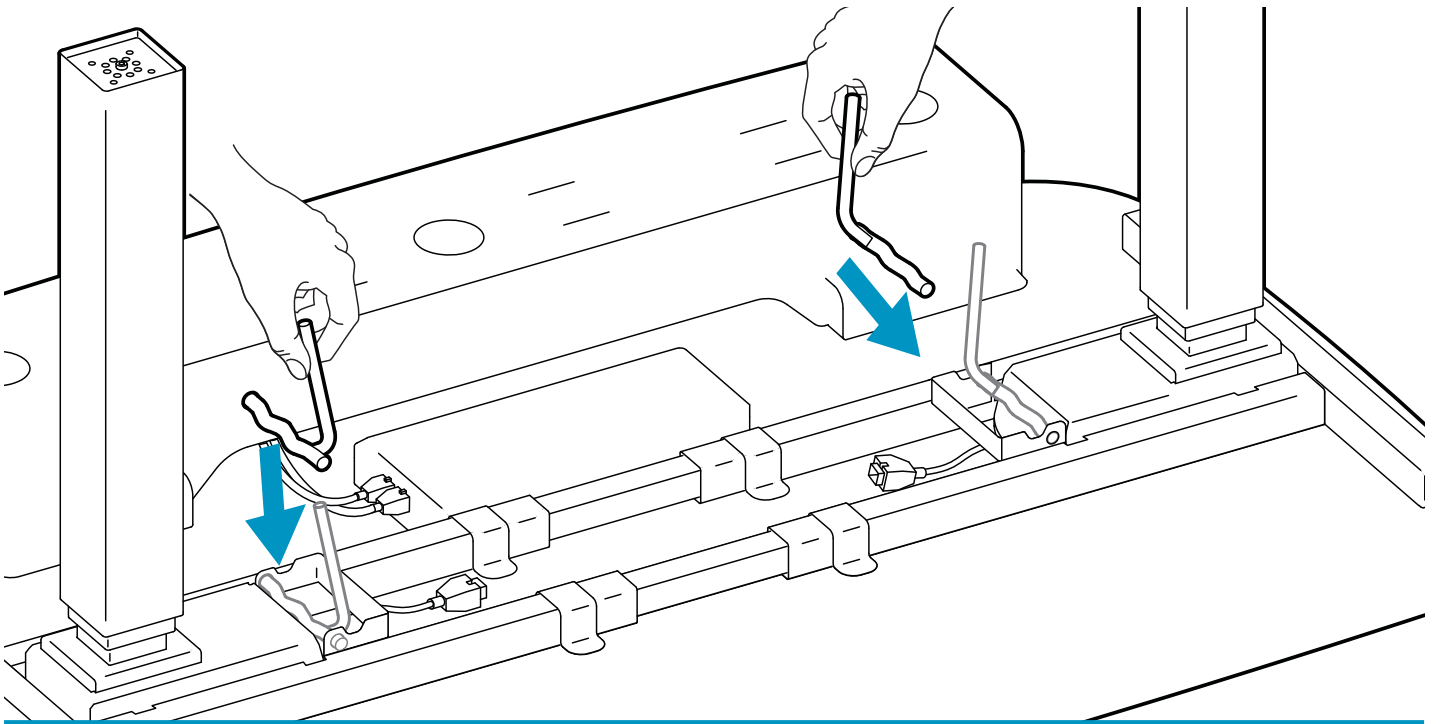

2

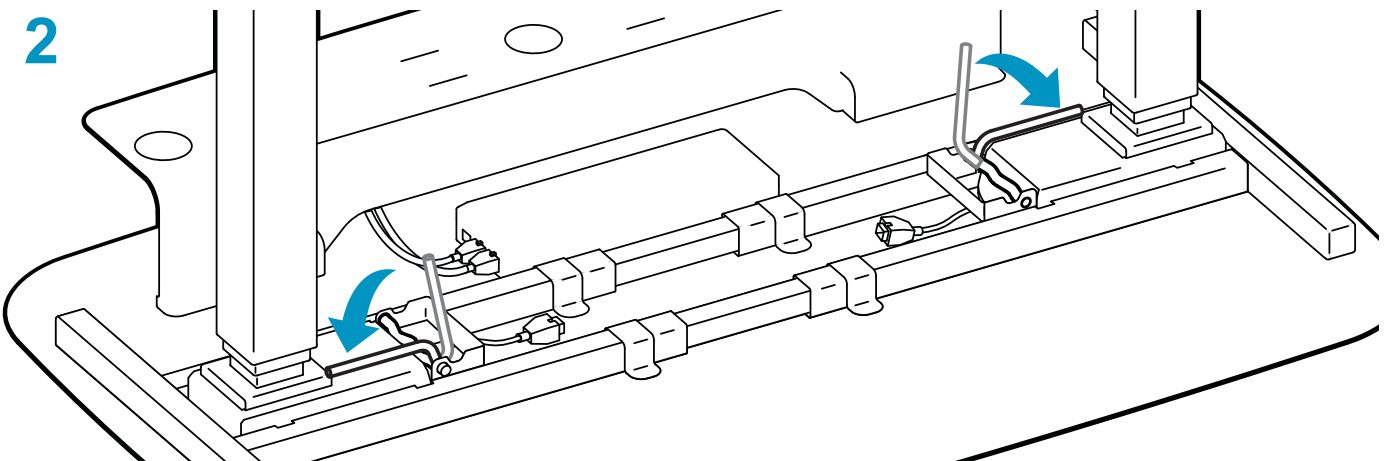

3

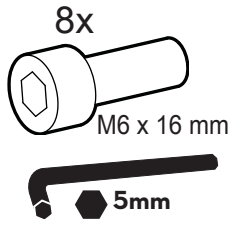

Make sure all screws are tight. Screws may loosen after others screws are tightened.

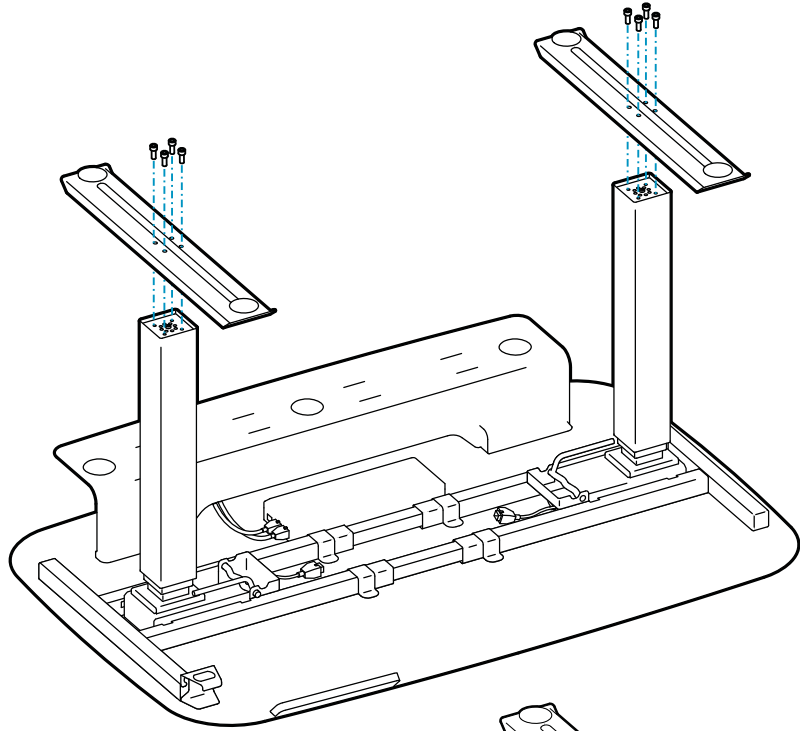

4

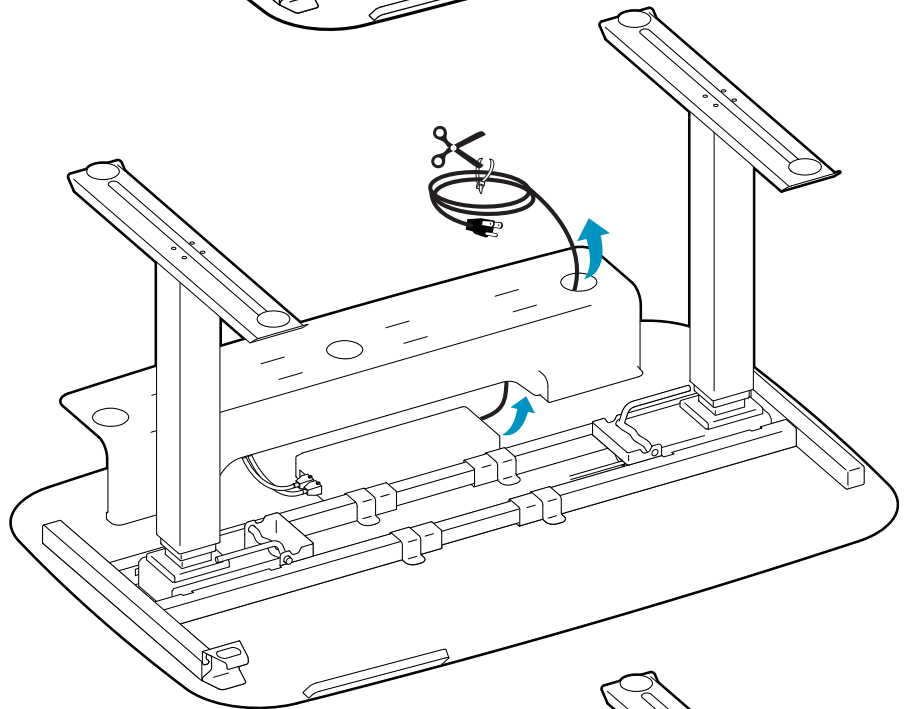

5

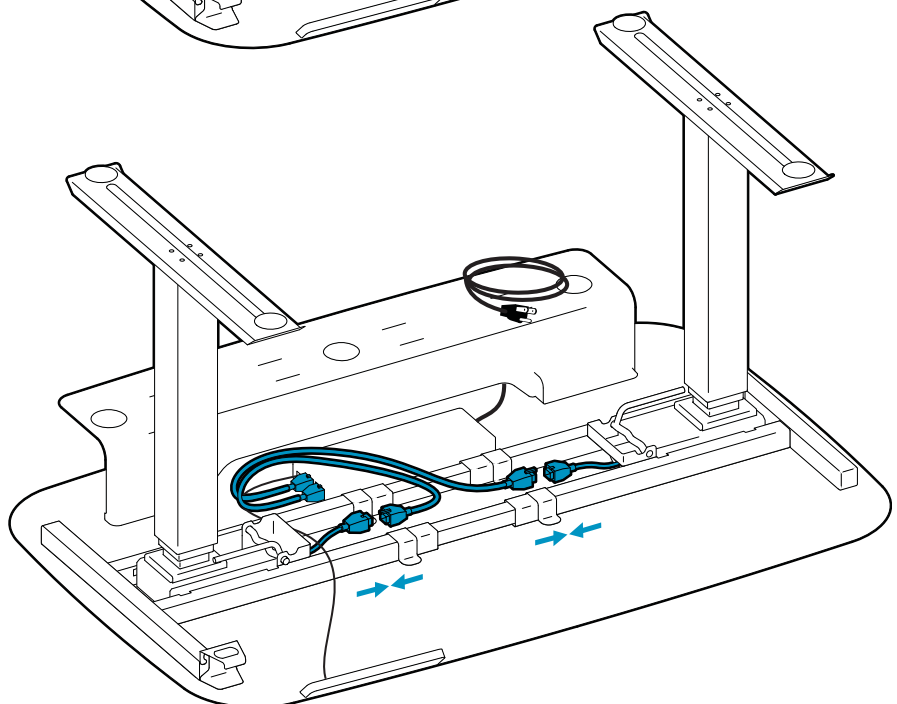

6



2 person lift.

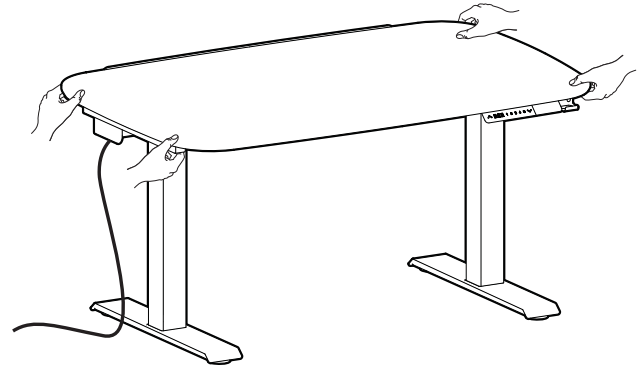
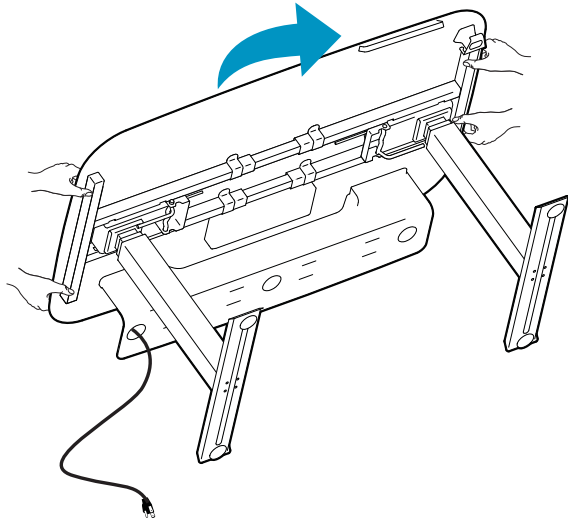

7

IMPORTANT! The Desk must be initialized before raising up and down for the first time. Follow 'Initialization Procedure' before raising or lowering the Desk.

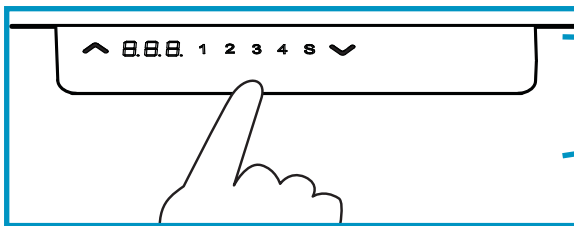
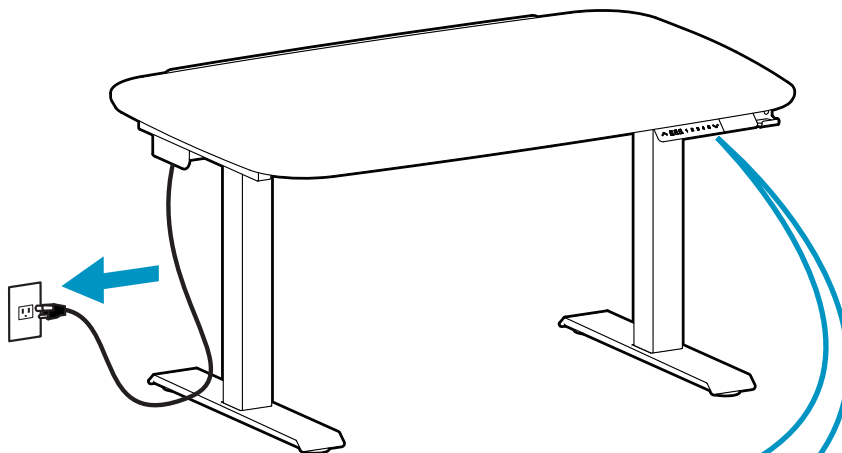

**Initialization Procedure:**

| STEP | OPERATION   | MOTION   |
|------|---|--|
| 1    | Press and hold $\wedge$ & $\vee$ simultaneously until legs stop moving. | Legs move down at half speed of normal operation to the lowest position and rebound 2-5 mm, then stop. |
| 2    | Release $\wedge$ & $\vee$ together.                                     | Initialization is complete.  |

The initialization procedure must be completed before the first running after the desk is installed or parts are replaced. When a re-initialization procedure is needed, unplug the desk from the wall for 30 seconds before re-initializing,

**Move Up and Down:**

| STEP | OPERATION                 | MOTION          |
|------|---------------------------|-----------------|
| 1    | Press and hold $\wedge$ . | Legs move up.   |
| 2    | Release $\wedge$ .        | Legs stop.      |
| 3    | Press and hold $\vee$ .   | Legs move down. |
| 4    | Release $\vee$ .          | Legs stop.      |

8

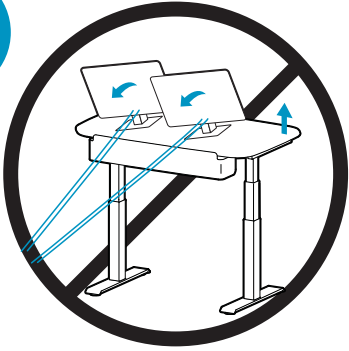

NOTE: Leave enough slack in cable to allow full range of motion.  
Caution: To avoid the potential to pinch cables it is important to follow the cable routing instructions in this manual. Failure to follow these instructions may result in equipment damage or personal injury.

REMARQUE : Laissez suffisamment de mou dans le cordon pour permettre au mouvement de haut en bas de se faire sur toute la hauteur.  
Attention : Pour éviter de risquer de pincer les câbles, il est important de suivre les instructions d'acheminement des câbles de ce manuel. Le non-respect de cette consigne peut entraîner des dommages matériels et/ou des blessures.

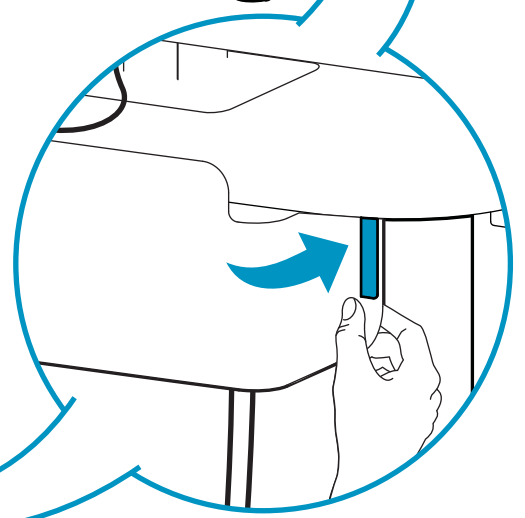
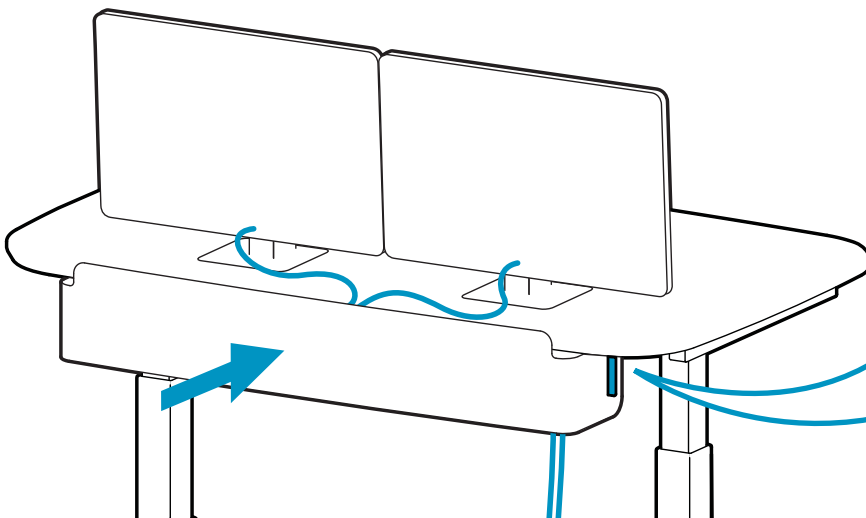
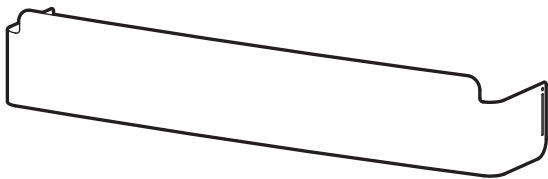
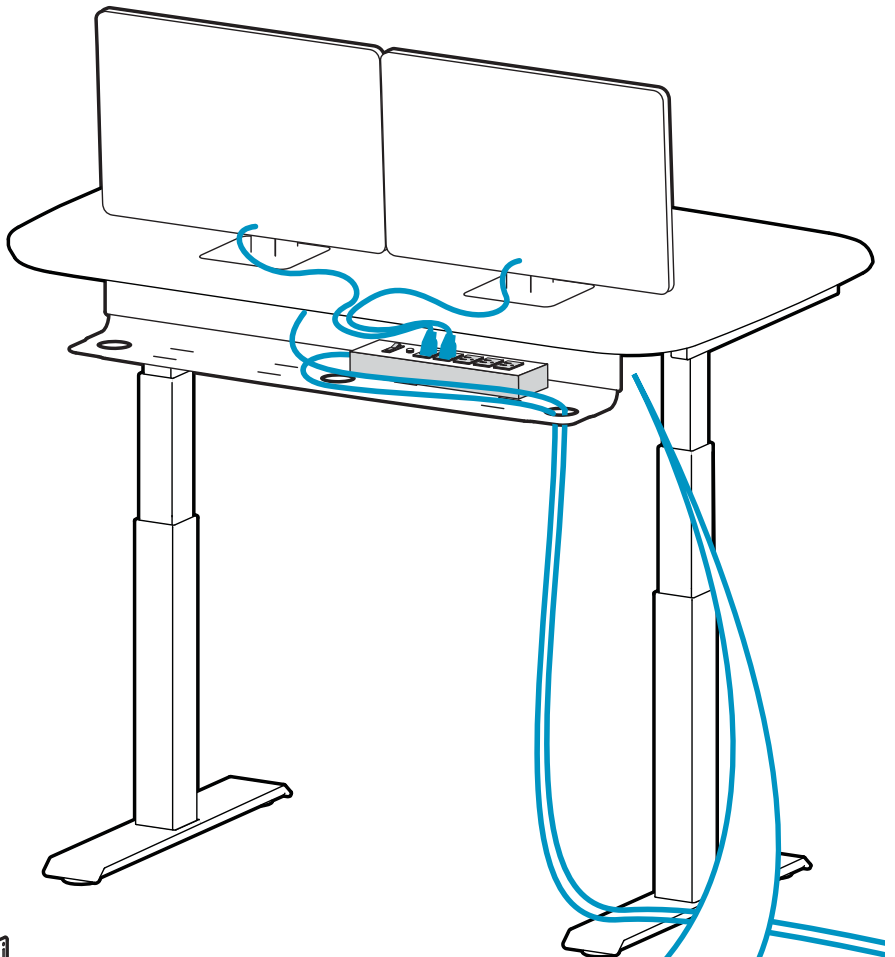
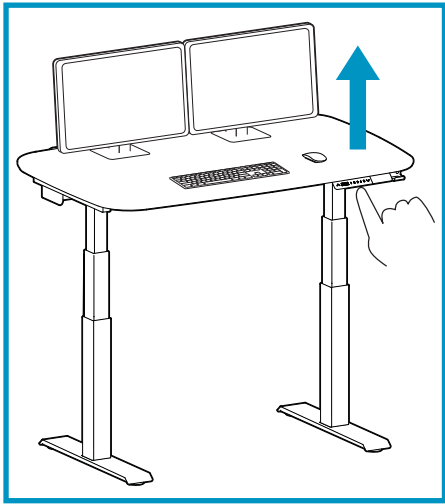

Yup, that's it. Really.

Now your WorkFit Electric Desk is ready for however you work best.

Toss the confetti and celebrate by using the new desk hook to pop open your beverage of choice.

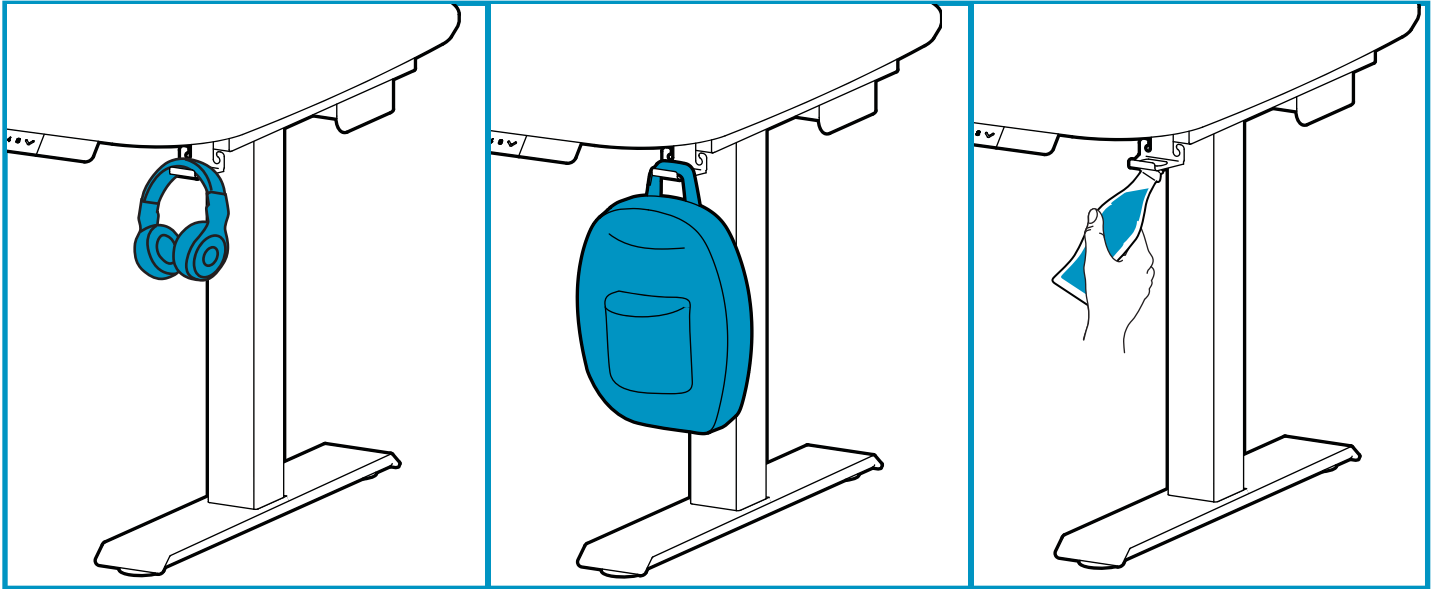

Important Information.

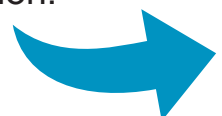

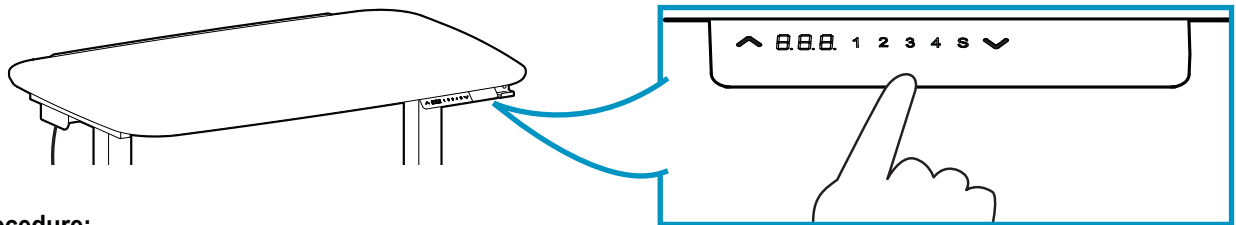

### Initialization Procedure:

| STEP | OPERATION   | MOTION   |
|------|---|--|
| 1    | Press and hold $\wedge$ & $\vee$ simultaneously until legs stop moving. | Legs move down at half speed of normal operation to the lowest position and rebound 2-5 mm, then stop. |
| 2    | Release $\wedge$ & $\vee$ together.                                     | Initialization in complete.  |

The initialization procedure must be completed before the first running after the desk is installed or parts are replaced. When a re-initialization procedure is needed, unplug the desk from the wall for 30 seconds before re-initializing,

### Move Up and Down:

| STEP | OPERATION                 | MOTION          |
|------|---------------------------|-----------------|
| 1    | Press and hold $\wedge$ . | Legs move up.   |
| 2    | Release $\wedge$ .        | Legs stop.      |
| 3    | Press and hold $\vee$ .   | Legs move down. |
| 4    | Release $\vee$ .          | Legs stop.      |

### Set Presets:

| STEP | OPERATION   | MOTION                                   |
|------|---|--|
| 1    | Press and hold $\wedge$ or $\vee$ to achieve desired desk height. | Legs move worksurface to desired height. |
| 2    | Press 'S' then press 1, 2, 3, or 4 within the next 3 seconds.     | Position 1, 2, 3, or 4 is saved.         |

### Move Desk Height to a Preset:

| STEP | OPERATION  | MOTION   |
|------|--|--|
| 1    | Press and hold 1, 2, 3, or 4 until legs stop moving. | Legs return to the corresponding position saved. |

### Switch Display from Inches to Centimeters:

| STEP | OPERATION   | MOTION   |
|------|---|--|
| 1    | Press and hold 'S' then press and hold $\vee$ and hold both down for 3 seconds. | The height information will be changed between centimeters and inches. |
| 2    | Release the buttons.  | Operation complete.  |

The display height changes in intervals of 0.5" or 1cm.

### Change the Height on the Display to Match the Actual Worksurface Height:

| STEP | OPERATION   | MOTION   |
|------|---|--|
| 1    | Set the worksurface to any height, recommended at the bottom position.                    | Measure the actual worksurface height and write down the number in inches or in centimeters. |
| 2    | Press and hold 'S' then press and hold $\wedge$ and hold both for 3 seconds.              | The first number on the display starts flashing.   |
| 3    | Release 'S' and $\wedge$ buttons then press $\wedge$ or $\vee$ to change the first digit. | The first digit is being increased or decreased to the first digit of your measurement.      |
| 4    | Press 'S'.  | The second digit on the display starts flashing.   |
| 5    | Press $\wedge$ or $\vee$ to change the second digit.                                      | The second digit is being increased or decreased to the second digit of your measurement.    |
| 6    | Press 'S'.  | The third digit on the display starts flashing.  |
| 7    | Press $\wedge$ or $\vee$ to change the third digit.                                       | The third digit is being increased or decreased to the third digit of your measurement.      |
| 8    | Press 'S'.  | Operation complete.  |



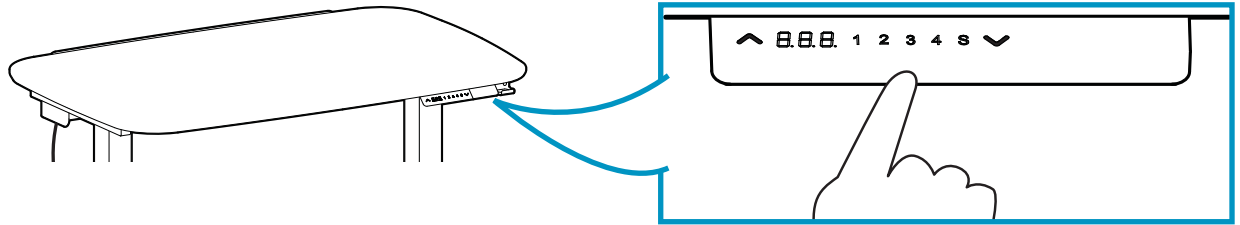

### Change the Bottom Position Height:

| STEP | OPERATION  | MOTION  |
|------|--|---|
| 1    | Press and hold ^ or v to achieve desired bottom position height.           | Run the legs to the height you want the bottom position to be.  |
| 2    | Press and hold 'S' then press and hold 1, hold both buttons for 3 seconds. | The letter 'L' shows on the display and means the position is locked at the lowest position that the worksurface can be moved to. |
| 3    | Release buttons.   | Operation completed.  |

### Unlock the Adjusted Bottom Position Height:

| STEP | OPERATION  | MOTION   |
|------|--|--|
| 1    | Press and hold 'S' then press and hold 1, hold both buttons for 3 seconds. | The letter 'C' shows on the display and means the bottom position is unlocked and can be moved through its full range of motion. |
| 2    | Release buttons.   | Operation completed.   |

### Error Codes:

| CODE | DESCRIPTION  | SOLUTION   |
|------|--|--|
| E01  | Leg malfunction  | 1. Cables came loose, Check if cables are all connected properly.<br>2. Inner parts of legs are broken, replace legs.  |
| E02  | Changing positions too often                                 | Desk has been moving for more than 1 min. Stop moving desk and let system cool down for 10 min.  |
| E03  | Weight added exceeds weight capacity                         | Remove excess weight from desk.  |
| E04  | Control box malfunction                                      | 1. Use in extreme environments will cause control box to malfunction. Re-initialize the desk. See 'Initialization Procedure'.<br>2. Stopping initialization process before complete will cause control box to malfunction. Re-initialize the desk. See 'Initialization Procedure'. |
| E05  | Display button is stuck                                      | 1. Check the status of the button, if stuck, then push to restore.<br>2. Replace keypad.   |
| E06  | Communication disconnected                                   | 1. Cable came loose between keypad/display and control box. Check if the cables are all connected properly.<br>2. Check to see if the control box works properly.  |
| E07  | The height of the desk has dropped below zero on the display | Raise the desk and change the height of desk on the display, see 'Change the Height on the Display to Match the Actual Worksurface Height'.  |





### Trouble Shooting:

| PROBLEM  | SOLUTION  |
|--|---|
| After connecting the power and pressing up or down the legs have no response.          | 1. Re-initialize the desk.<br>2. Check if the cables are all connected properly.<br>3. Contact Customer Care.                       |
| After connecting the power and holding up and down together the legs have no response. | 1. Check if the cables are all connected properly.<br>2. Contact Customer Care.   |
| The legs rise slowly.  | 1. Check if the input power is the correct rating.<br>2. Contact Customer Care.   |
| The legs dont move in the direction you're pressing on the keypad.                     | Contact Customer Care.  |
| Only one leg is moving.  | 1. Check if the cables are all connected properly.<br>2. Contact Customer Care.   |
| Legs only move down and not up.  | 1. Re-initialize the desk. See 'Initialization Procedure'.<br>2. Contact Customer Care.   |
| Desk moves down on its own.  | 1. Make sure the added weight does not exceed the weight capacity.<br>2. Contact Customer Care.                                     |
| Desk goes into the initialization process frequently.                                  | 1. Make sure the added weight does not exceed the weight capacity.<br>2. Check the noise of the motor.<br>3. Contact Customer Care. |

# Safety

## Hazard Symbols Review

These symbols alert users of a safety condition that demands attention. All users should be able to recognize and understand the significance of the following Safety Hazards if encountered on the product or within the documentation. Children who are not able to recognize and respond appropriately to Safety Alerts should not use this product without adult supervision!

| Symbol  | Signal Word  | Level of Hazard   |
|---|--------------|---|
|   | INSTRUCTIONS | Refer to instruction manual/booklet.<br>Follow instructions for use.  |
|  | CAUTION      | A CAUTION indicates either potential damage to hardware or loss of data and tells you how to avoid the problem. |
|  | WARNING      | A WARNING indicates either potential for property damage, personal injury, or death.                            |
|  | DANGER       | A DANGER indicates a hazardous situation that, if not avoided, will result in death or serious injury.          |

There are specific risks associated with the use of equipment having power cables. You must be aware of, and avoid these risks when located in close proximity to children.

 **WARNING:** Failure to observe the following Electrical Safety notices can result in fire or death by electric shock.

Electrical cables can be hazardous. Misuse can result in fire or death by electrical shock.

- Inspect power cables thoroughly before each use.
- Do not use cables that are damaged.
- Insert the plug completely into the outlet.
- Grasp the plug to remove from the outlet.
- Do not unplug by pulling on the cable.
- Do not use excessive force to make connections.
- Do not plug the cable into an extension cable.
- Do not remove, bend or modify any metal prongs or pins of cable.
- Do not drive, drag or place objects over the cable.
- Do not walk on the cable.
- Avoid overheating. Uncoil the cable and do not cover it with any material.
- Do not run cable through doorways, holes in ceilings, walls or floors.

Keep away from water.

- Do not use it when wet.
- Do not place in close proximity to flammable liquids or gases.

The power disconnect for this equipment is the AC power cable.

Therefore the socket outlet should be easily accessible and should be installed near the equipment.

Electrical devices are not toys. Children are often unaware of the hazards associated with electrical devices, so this unit must always be used by adults or with adult supervision. User Must be aware of the surrounding environment while operating the this product.

Do not use this unit outdoors.

Liquids should not be stored in, set on or placed inside this unit.

Never unplug this product from the outlet when your hands are wet.

Ergotron does not accept any liability for damage if the unit is misused, incorrectly operated or inadequately repaired. Under these circumstances the warranty will be void.

Any modifications made to this device that are not approved, may void the authority granted to the user by the FCC to operate this equipment.

This product is for use on a nominal 120-volt circuit and has a grounding plug that looks like the one shown below. make sure that the product is connected to an outlet having the same configuration as the plug. No adapter should be used with this product.

Electrical Rating:  
120VAC~ 60Hz, 400W

Environmental  
Temperature range:  
Operating 0° to 30°C (32° to 86°F)  
Storage -40° to 60°C (-40° to 140°F)

Relative humidity (maximum):  
Operating 10%–90% (non condensing)  
Storage 5%–95% (non condensing)

Altitude (maximum): 2000 m (6,562 ft)

Certification:  
UL 962 Standard for Household and Commercial Furnishings,  
CAN/CSA C22 2 No. 203.2-14  
ICES-003 Issue 5, Class A  
FCC Part 15 Class A  
RoHS and REACH compliant material used.

This device complies with Part 15 of the FCC Rules. Operation is subject to the following two conditions:

- 1) This device may not cause harmful interference.
- 2) This device must accept any interference received, including interference that may cause undesired operation.

CAN ICES3(A)/NMB-3(A).

Changes or modifications not expressly approved by the Ergotron could void the user's authority to operate the equipment.

Intended for institutional use.

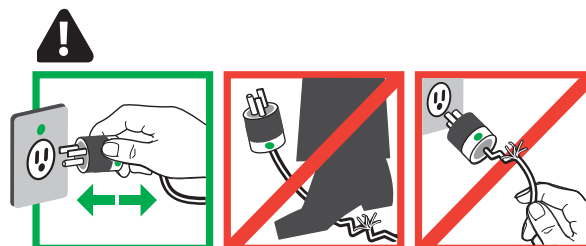





**DANGER!** Electrical cables can be hazardous. Misuse can result in fire or death by electrical shock.

# Sécurité

## Examen des symboles de danger

Ces symboles avertissent les utilisateurs de conditions de sécurité nécessitant leur attention. Les utilisateurs doivent être en mesure de reconnaître et de comprendre ce que signifient les risques pour la sécurité suivants s'ils les voient sur le produit ou dans la documentation du produit. Les enfants qui ne peuvent pas reconnaître ni répondre correctement aux avertissements de sécurité ne doivent pas utiliser le produit sans la supervision d'un adulte !

| Symbole   | Mot signal    | Niveau de danger  |
|---|---------------|---|
|   | INSTRUCTIONS  | Refer to instruction manual/booklet.<br>Follow instructions for use.  |
|  | ATTENTION     | La mention ATTENTION indique la possibilité de dommages matériels ou de perte de données ainsi que la manière d'éviter le problème. |
|  | AVERTISSEMENT | Un AVERTISSEMENT indique la possibilité de blessures personnelles potentiellement mortelles et de dommages matériels.               |
|  | DANGER        | Un DANGER indique une situation dangereuse qui, si elle n'est pas évitée, entraînera la mort ou des blessures graves.               |

Il existe des risques spécifiques liés à l'utilisation d'équipements munis de câbles d'alimentation. Vous devez être conscient des risques, et savoir les éviter lorsque le produit est situé à proximité d'enfants.

 **AVERTISSEMENT** : le non-respect des consignes de sécurité électriques suivantes peut provoquer un incendie ou la mort par électrocution.

Les câbles électriques peuvent être dangereux. Une mauvaise utilisation peut déclencher un incendie ou entraîner la mort par électrocution.

- Bipolaire/Fusion Neutre
- Inspectez soigneusement les câbles d'alimentation avant chaque utilisation.
- N'utilisez pas de câbles qui sont endommagés.
- Insérez la fiche complètement dans la prise.
- Saisissez la fiche pour la retirer de la prise.
- Ne débranchez pas la fiche en tirant sur le câble.
- Ne forcez pas pour effectuer les branchements.
- Ne branchez pas le câble dans une rallonge.
- Ne retirez pas, ne pliez pas et ne modifiez pas les broches métalliques ou les fiches du câble.
- Ne roulez pas sur le câble, ne le traînez pas et ne posez pas d'objets dessus.
- Ne marchez pas sur le câble.
- Évitez toute surchauffe. Déroulez le câble et ne le couvrez pas avec quoi que ce soit.
- Ne faites pas passer le câble par des cadres de porte ou des trous dans le plafond, les murs ou les planchers.

Tenez à l'écart de l'eau.

- Ne l'utilisez pas lorsqu'il est mouillé.
- Ne le placez pas à proximité de liquides ou de gaz inflammables.

Cet appareil est mis hors tension en débranchant le câble d'alimentation secteur.

La prise de courant doit donc être installée près de l'appareil et être facilement accessible.

Les appareils électriques ne sont pas des jouets. Les enfants sont souvent inconscients des risques associés aux appareils électriques,

par conséquent cet appareil doit toujours être utilisé par des adultes ou sous la supervision d'un adulte.

N'utilisez pas cet appareil en plein air.

Les liquides ne doivent pas être stockés à l'intérieur, placés sur ou dans cet appareil.

Ne débranchez jamais ce produit de la prise quand vos mains sont mouillées.

Ergotron décline toute responsabilité en cas de dommages si l'appareil fait l'objet d'une utilisation incorrecte, contraire à l'emploi ou s'il a été réparé inadéquatement. Dans ces circonstances, la garantie sera annulée.

Toute modification apportée à cet appareil qui n'est pas approuvée peut annuler le droit d'utiliser cet équipement accordée à l'utilisateur par la FCC.

Ce produit est destiné à être utilisé sur un circuit nominal de 120 volts et possède une fiche de mise à la terre qui ressemble à celle illustrée ci-dessous. Assurez-vous que le produit est connecté à une prise ayant la même configuration que la fiche. Aucun adaptateur ne doit être utilisé avec ce produit.

Puissance électrique :  
120 V~ 60 Hz, 12 A

Environnement

Plage de températures de fonctionnement :

En service : de 0 à 30 °C (32° à 86°F)

Rangement : de -40 à 60 °C (-40° à 140°F)

Humidité relative (maximale) :

En service : de 10 à 90 % (sans condensation)

Rangement : de 5 à 95 % (sans condensation)

Altitude (maximale) : 2 000 m (6 562 pi)

Certification :

Norme UL 962 pour l'ameublement domestique et commercial,  
CAN/CSA C22.2 n° 203.2-14.

ICES-003 Issue 5, Classe A

FCC Partie 15 Classe A

Matériaux utilisés en fabrication conformes à RoHS et REACH.

Cet appareil est conforme à la section 15 des règlements FCC.

Son opération est soumise aux deux conditions suivantes :

1) Cet appareil ne doit pas causer d'interférences nuisibles.

2) Cet appareil doit accepter toute interférence reçue, y compris les interférences susceptibles d'en altérer le fonctionnement.

CAN ICES-3(A) / NMB-3(A).

Tout changement aux modifications qui n'est pas expressément approuvé par Ergotron peut annuler l'autorité dont dispose l'utilisateur de faire fonctionner cet équipement.

Conçu pour un usage institutionnel.



**DANGER!** Les câbles électriques peuvent être dangereux. Une mauvaise utilisation peut entraîner un incendie ou la mort par électrocution.

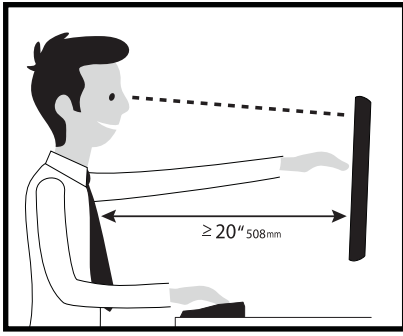

Learn more about ergonomic computer use at: [www.ergotron.com/ergonomics](http://www.ergotron.com/ergonomics)



2 Options of Worksurface Width:

46" or 58"  
(117 or 147 cm)

23"- 49"  
(58-124 cm)

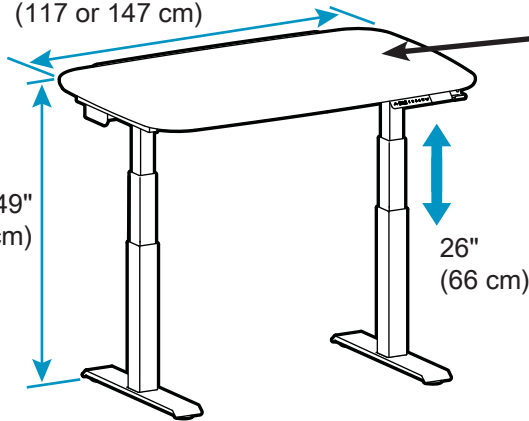

Weight Capacity:  
200 lbs. (90.72 kg)



CAUTION: DO NOT EXCEED MAXIMUM LISTED WEIGHT CAPACITY. SERIOUS INJURY OR PROPERTY DAMAGE MAY OCCUR!

ATTENTION : NE PAS DÉPASSER LA CAPACITÉ NOMINALE MAXIMALE MENTIONNÉE. DE SÉRIEUSES BLESSURES OU DES DOMMAGES MATÉRIELS POURRAIENT SE PRODUIRE !

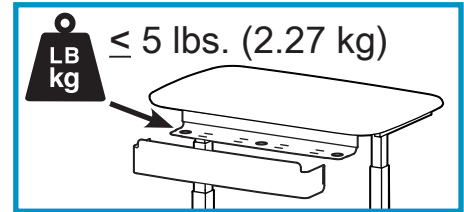

Hook can be relocated to either side of desk.

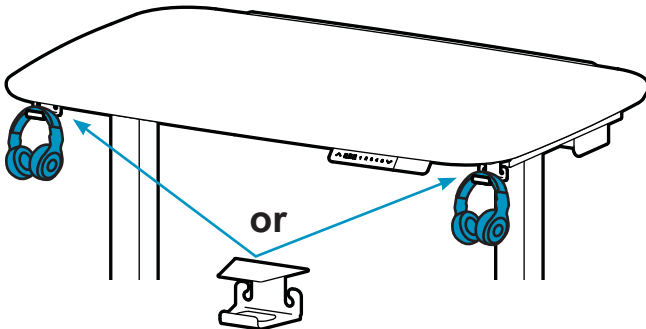

For Warranty visit: [www.ergotron.com/warranty](http://www.ergotron.com/warranty)

For Service visit: [www.ergotron.com](http://www.ergotron.com)

For local customer care phone numbers visit: <http://contact.ergotron.com>

NOTE: When contacting customer service, reference the serial number.

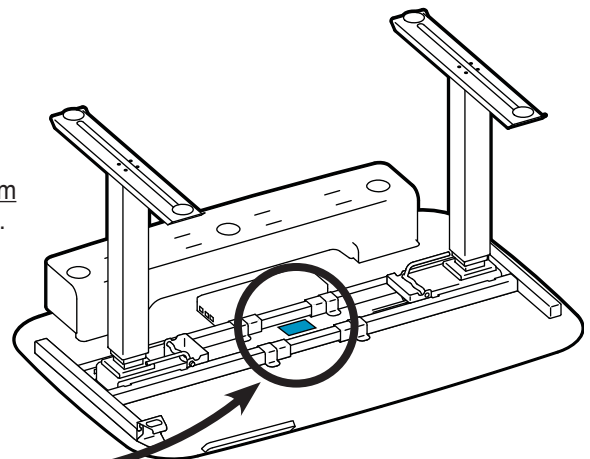

# ergotron®

[www.ergotron.com](http://www.ergotron.com) | USA: 1-800-888-8458 |

© 2019 Ergotron, Inc. All rights reserved. WorkFit™ is a registered trademark of Ergotron, Inc.

While Ergotron, Inc. makes every effort to provide accurate and complete information on the installation and use of its products, it will not be held liable for any editorial errors or omissions (including those made in the process of translation from English to another language), or for incidental, special or consequential damages of any nature resulting from furnishing this instruction and performance of equipment in connection with this instruction. Ergotron, Inc. reserves the right to make changes in the product design and/or product documentation without notification to its users. For the most current product information, or to know if this document is available in languages other than those herein, please contact Ergotron. No part of this publication may be reproduced, stored in a retrieval system, or transmitted in any form or by any means, electronic, mechanical, photocopying, recording or otherwise without the prior written consent of Ergotron, Inc., 1181 Trapp Road, Eagan, Minnesota, 55121, USA Patents Pending and Patented U.S. & Foreign. Ergotron is a registered trademark of Ergotron, Inc.